

PVC SLOTTED SCREENS

Slotted screens are obtained by making cuts all over the pvc pipe in order to exploit the screen collecting capability to maximum level. Slots are horizontal to pipes generatrices. Data show that horizontal openings are very hydraulically efficient and provide high collapse resistance thanks to the arc shape of the material around them. PVC slotted screens are usually used in fine soils to build up artesian wells, for drainages etc. The product is manufactured according to customer needs: the slots length and number depend on the requested open area, moreover, cuts can be made on one, two, three or four sides of the pipe (see pic. 1 and 2), whereas the slots width is related to soil granulometry.

OUR RANGE

Diameters: from 60 to 630 mm

Wall thicknesses: from 4,2 to 24,0 mm

Slots: from 0,2 to 5,0 mm

Connections: M/F threaded with socket, flush joints, glue connections upon request.

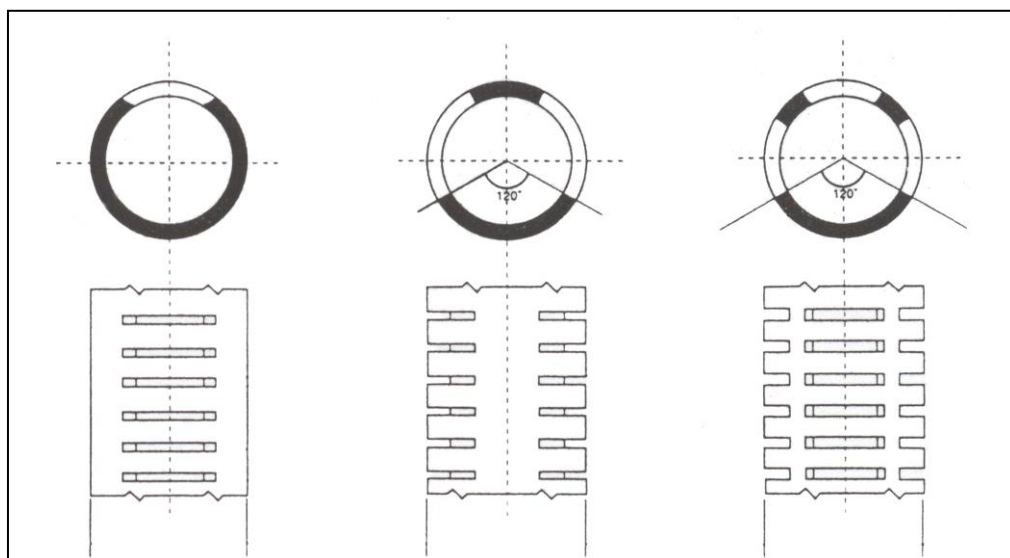

Pic. 1

Section image of cuts made on one, two and three sides.

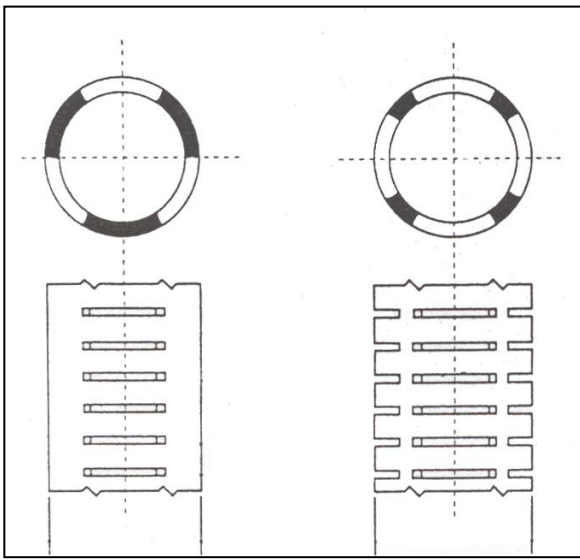

Pic. 2
Section image of cuts made on three and four sides

SLOTTED SCREENS THEORETICAL YIELD

OUTSIDE DIAMETER		SLOT WIDTH - mm													
		0,20 – 0,25		0,30 – 0,40		0,50 – 0,70		1,00		1,50		2,00		3,00	
mm	inches	Open area	m ³ /h/mt	Open area	m ³ /h/mt	Open area	m ³ /h/mt	Open area	m ³ /h/mt	Open area	m ³ /h/mt	Open area	m ³ /h/mt	Open area	m ³ /h/mt
60	2"	3,50 %	0,60	5,00 %	0,80	6,00 %	1,00	8,50 %	1,50	9,20 %	1,60	11,0 %	2,00	12,00 %	2,10
75	2" 1/2	3,50 %	0,75	5,00 %	1,00	6,00 %	1,30	8,50 %	1,80	9,20 %	1,90	11,0 %	2,30	12,00 %	2,50
89	3"	3,50 %	0,90	5,00 %	1,30	6,00 %	1,50	8,50 %	2,20	9,20 %	2,50	11,0 %	2,80	12,00 %	3,00
114	4"	3,50 %	1,10	5,00 %	1,60	6,00 %	2,00	8,50 %	2,70	9,20 %	3,00	11,0 %	3,50	12,00 %	4,00
125	4" 1/2	3,50 %	1,30	5,00 %	1,80	6,00 %	2,20	8,50 %	3,00	9,20 %	3,30	11,0 %	3,80	12,00 %	4,50
140	5"	4,00 %	1,60	5,00 %	2,20	6,00 %	2,40	7,50 %	3,00	8,00 %	3,30	11,0 %	4,50	12,00 %	5,00
160	6"			5,00 %	2,30	6,00 %	2,70	7,50 %	3,80	8,00 %	4,00	11,0 %	5,00	12,0 0%	6,00
165	--			5,00%	2,30	5,50%	2,70	7,50%	3,80	8,00%	4,00	11,00%	5,00	12,00%	6,00
170	--			5,00 %	2,30	5,50 %	2,70	7,50 %	3,80	8,00 %	4,50	11,0 %	5,50	12,00 %	6,50
180	6" 1/2			5,00 %	2,50	5,50 %	2,90	7,50 %	4,00	8,00 %	4,80	11,0 %	5,90	12,0 0%	7,00
200	7"			4,50 %	2,50	5,50 %	2,90	7,50 %	4,50	8,00 %	5,00	11,0 %	6,50	12,00 %	7,50
225	8"					5,50 %	3,40	7,50 %	5,00	8,00 %	5,50	11,0 %	7,50	12,00 %	9,00
250	9"					4,50 %	3,50	7,00 %	5,00	8,00 %	6,00	10,0 %	7,50	12,00 %	9,00
280	10"					4,50 %	4,00	7,00 %	5,90	8,00 %	6,50	10,0 %	8,20	12,00 %	10,30
315	--							7,00 %	7,00	8,00 %	7,80	10,0 %	9,50	12,0 %	11,50
330	12"							7,00 %	7,00	8,00 %	7,80	10,0 %	9,50	12,00 %	11,50
400	14"							7,00%	8,00	8,00%	9,50	10,0%	12,00	12,00%	15,00
450	--													3,5 %*	----
500	--													4,0 %*	----
630	--													3,8 %*	----

* Slot 5,0 mm